

**CAPACITIVE FUEL
LEVEL
SENSOR
ESCORT TD-600**

DATASHEET

Serial № S

Date D



1 GENERAL INFORMATION ABOUT PRODUCT

1.1. The meter (sensor) ESCORT TD-600 determines the light oil filling level in tanks (storage tanks). It is used in automotive and tractor equipment as a fuel level meter, in industry - as a level meter for any light oil products.

1.2. The meter converts the calculated fuel level to a digital code.

Depending on the operation mode, the meter transmits the value via the RS-485, RS-232 interface or as an analog, periodic, frequency signals.

1.3. Depending on the modification, it has analog signal outputs for connection to the level needle indicator and for indication of emergency fuel residue.

1.4. DO NOT USE THE METER FOR MEASUREMENT OF ELECTRICALLY CONDUCTIVE LIQUID LEVEL (E.G. WATER, DAIRY PRODUCTS).

1.5. DO NOT DISASSEMBLE THE METER!

1.6. DO NOT EXCEED THE PERFORMANCE SPECIFICATIONS SPECIFIED HEREIN!

1.7. PREVENT MECHANICAL DAMAGE TO METER PARTS, MOUNTING WIRES AND CABLES DURING THE INSTALLATION AND OPERATION.

2 TECHNICAL CHARACTERISTICS

Table 1 – Technical characteristics ESCORT TD-600

Name	Value / Units
Power supply voltage	7 ... 80V
Recommended supply voltage	12...36V
Output resistance of level indicator *	0 ... 110 Ohm ($\pm 10\%$)
Minimum measured fuel level * (emergency fuel)	$10 \pm 2 \%$
Reduced measurement error in the effective range	Up to 1% UML**
Operating modes	analog, frequency, digital
Digital mode: - interface - communication protocol - data rate	RS-485 and RS-232 LLS 19200 bps
Output signal range: - digital signal - frequency mode - analog mode***	0 ... 4095 un. 300 ... 4395 Hz 0.25 ... 9 V
Ingress protection rating acc. IEC 60529:2013	IP69S
Electrical strength of galvanic isolation, not less than	2500 V
Electric shock protection acc. IEC 61140:2016	class III

Operating conditions: - ambient temperature - atmospheric pressure	- 60 ... + 85 oC 84 ... 106.7 kPa
--	--------------------------------------

Continuation of the table 1

Name	Value / Units
Dimensions	max. 80x80x(L+21) mm, where L is the meter length
Nominal meter length	on the label (pasted in the Certificate)
Weight	max. 0.5 kg
* in modification without RS232	
**UML - upper limit of measurement	
*** at a supply voltage exceeding 12V	

3 SCOPE

Table 2 - Scope ESCORT TD-600

Name	Quantity	Ser. number	Notes
Ver. 1:			
Sensor ESCORT TD-600	1		
Datasheet	1		in electronic form
Ver. 2:			
Sensor ESCORT TD-600	1		
Installation kit	1		
Datasheet	1		in electronic form

4 SAFETY PRECAUTIONS

4.1. Observe general safety instructions for electric installations during installation, operation and maintenance of the meter.

5 SERVICE AND SHELF LIFE, WARRANTY

5.1. Guaranteed service life is 5 years after shipment from the manufacturer.

5.2. Service life is 10 years.

5.3. The manufacturer guarantees that the transducer meets the specification requirements, if the user observes operating, transportation and storage conditions.

5.4. If any defect is found, contact the manufacturer.

5.5. The warranty does not cover defects caused by failure to follow the operation, storage and transportation conditions.

5.6. The manufacturer reserves the right to make changes in design and complete set product without prior notice to the customer.

6 DATE OF MANUFACTURE AND ACCEPTANCE CERTIFICATE

The meter ESCORT TD-600 ser. No. _____S_____ is manufactured in accordance with the current technical documentation and is declared to be ready for operation.

7 PACKING CERTIFICATE

The meter ESCORT TD-600 ser. No. _____S_____ is packed in accordance with the current technical documentation.

8 INSTALLATION CERTIFICATE

Capacitive fuel level sensor ESCORT TD-600 S/n _____S_____ is installed in accordance with the current technical documentation for the device:

Name serial number / public number

signature Full name day, month, year

Notes

9 TRANSPORTATION AND STORAGE

9.1. The product shall be transported in the original packaging in enclosed vehicles. Store in a dry place at a temperature of -20 to +30 °C and humidity up to 75 %. Conductive dust, aggressive substances and their vapours causing corrosion of parts and destruction of electrical insulation of transducers are not allowed in storage rooms.

10 DISPOSAL

10.1. The device does not include environmentally hazardous elements.

10.2. The device does not contain precious metals in the amount to be accounted for.

11 TIPS FOR INSTALLATION ON AUTOMOTIVE AND TRACTOR EQUIPMENT

11.1. The meter length should be specified when ordering.

11.2. If necessary, the measuring tubes should be cut with a hacksaw, avoiding the chip falling into the measuring part. The minimum residual length of the measuring part shall be at least 150 mm.

11.3. Install the centralizer from the set of installation parts (see Annexes).

11.4. Install the upper and lower limit levels using USB-RS485 interface converter and ESCORT program. For details, refer to the Operating manual.

11.5. Install the meter using a sealing gasket between the sensor flange and the tank surface. If necessary, use an additional oil-and-petrol resistant sealant for cars.

11.6. When installing the meter not in the regular installation point, see details of installation work in the Annexes.

11.7. If there is no additional isolation (corrugated tube) of the meter cable and the connecting cable, lay them in additional isolation (corrugated tube), avoiding contact with the heating parts of the automotive equipment units.

11.8. Standard wires of the fuel system can be used to connect the fuel level indicator needle and the remaining reserve lamp.

11.9. Connect fuse 1A (see Annexes, FU1). The fuse is placed in the cab.

11.10. Isolate all unused wires to prevent their short circuit to each other and to other circuits.

11.11. Additional information is given in the Annexes.

ATTENTION! Calibration of the upper level of the sensor should be made from the drain hole (10 mm from the sensor housing).

ATTENTION! The sensor longer than 2 m must be installed with a bottom detent included in the installation kit.

ANNEX 1 Connection diagram of the meter in programming mode

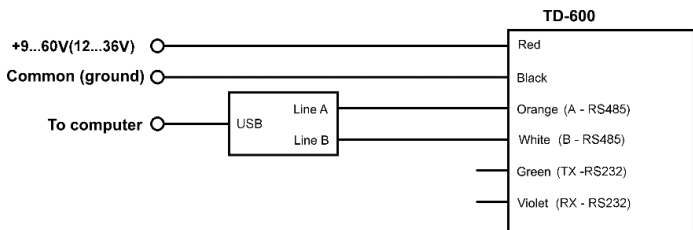

ANNEX 2 Connection diagram of the meter in RS-485 mode

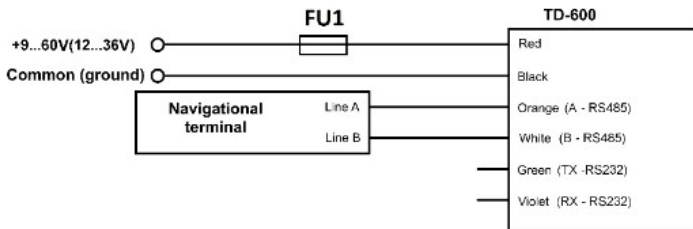

ANNEX 3 Connection diagram of the meter in analog mode

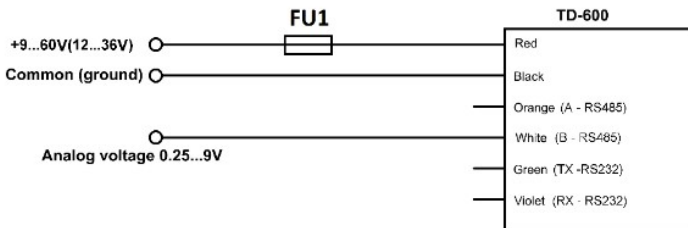

ANNEX 4 Connection diagram of the meter in frequency mode

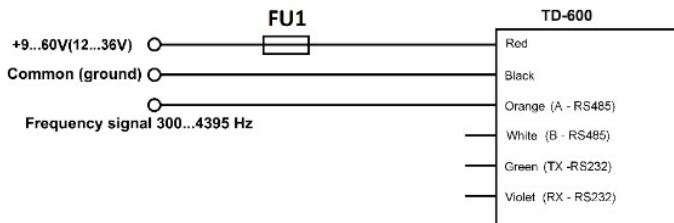

ANNEX 5 Connection diagram of the meter in RS-232 mode

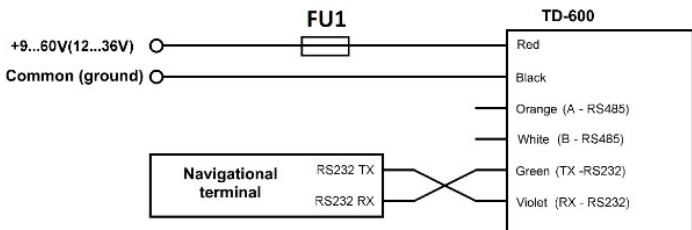

ANNEX 6 Dimensions for the meter installation not in the standard installation point

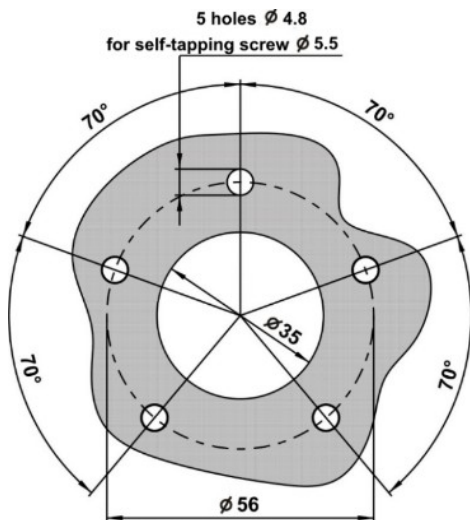

ANNEX 7 Installation of the meter on the tank

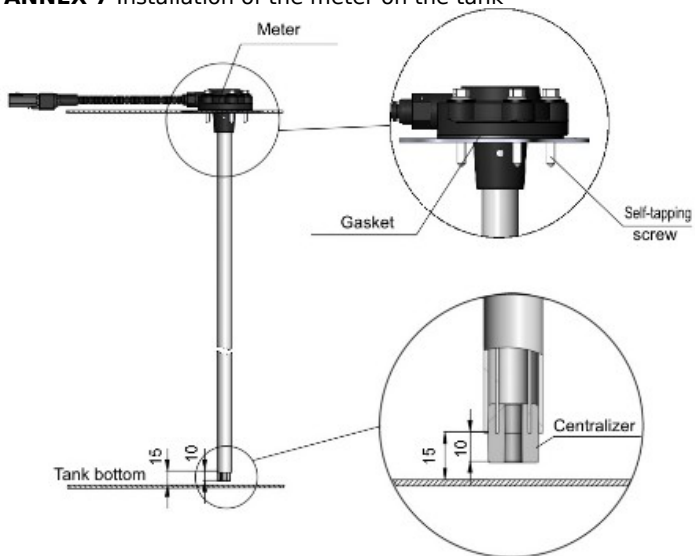

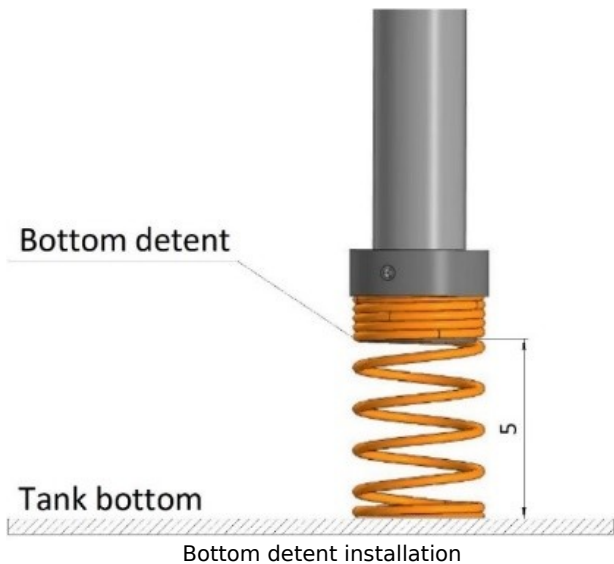

ANNEX 8 Meter head and cable connection sealing methods

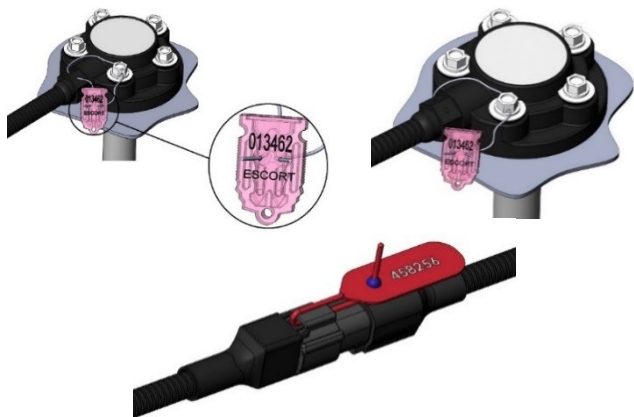

FOR NOTES